

FRONT SIDE AUTOMATIC STITCHING MACHINE

SMA110S & 110SP

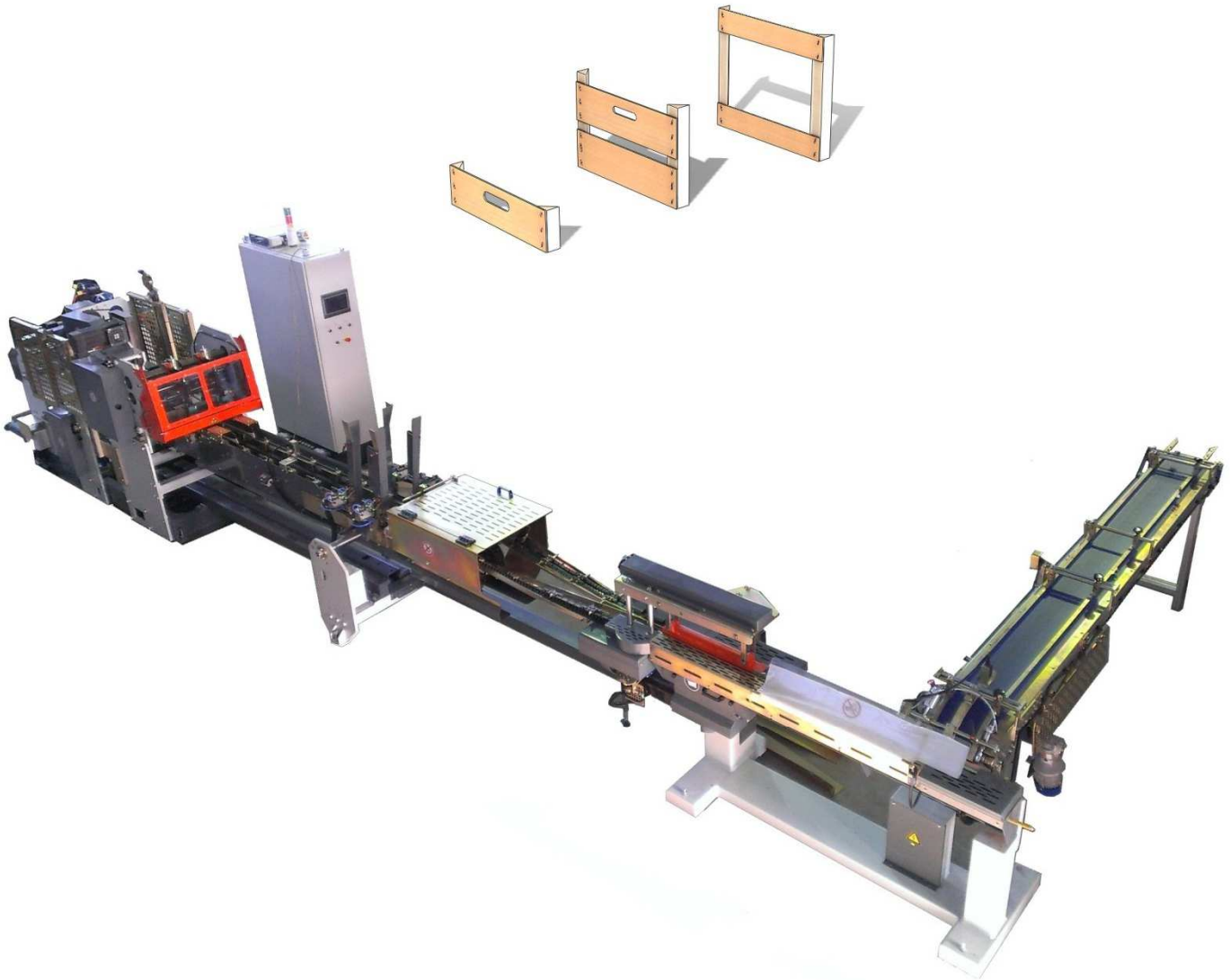

NOURIS
www.nouris.gr

➤ DIMENSIONS:

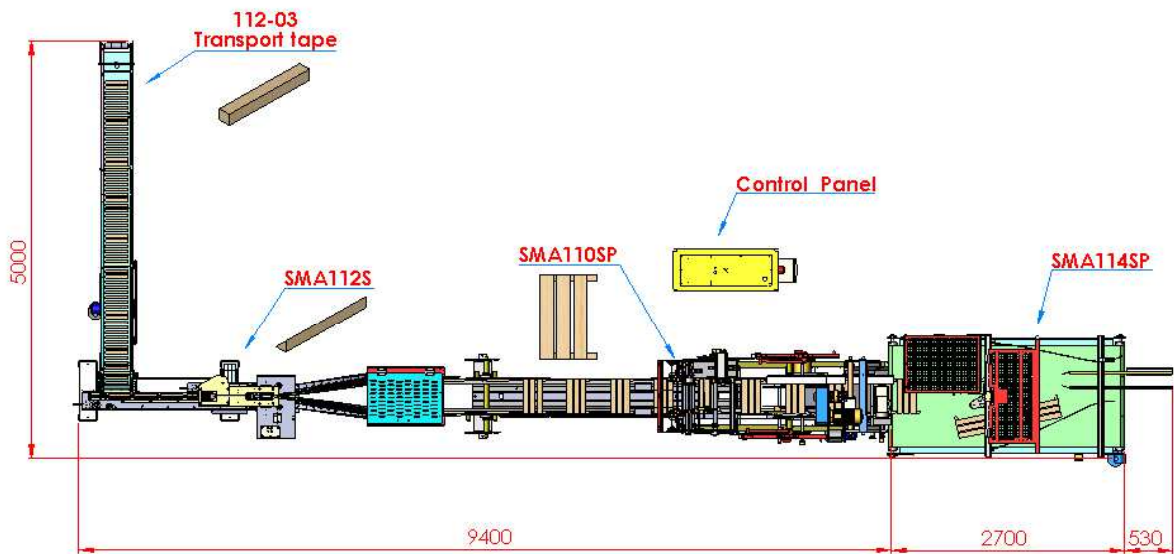

➤ GENERAL FEATURES:

- Two (2) of high quality and precision stitching heads.
- Quick and easy change of settings referred to stitches, production and of other operations.
- High technology SERVO motors are used for the stitching heads movement.
- Operator screen type of a 10" touch screen.
- Ability to add press, to produce the handhold.
- Ability to connect with SMA111 at the entrance.
- Ability to connect with SMA135 or SMA 115 at the exit.
- Ability to choose (before order) at which side the blocks will enter.
- Security declarations CE.



➤ **TECHNICAL CHARACTERISTICS SMA110S & SP :**

Total Installed Power	17kW
Current	3 X 400V-50Hz-63A max
Air pressure (min)	6bar
Wire diameter	1,2mm (No7)
Production (max)	5500 front sides/hour
Weight	3500 kg

➤ **FRONT SIDES DIMENSIONS :**

SMA110S or 110SP model can produce a range of front sides depending on your needs. Common dimensions are given below.

A	185-400mm
B	60-260mm
C	26-35mm

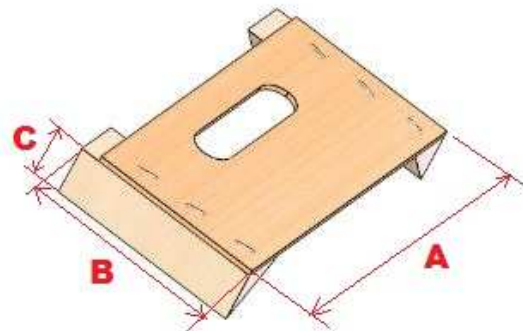

M.NOURIS & SONS O.E

14th km, old National Road Thessaloniki – Veria, P.O. Box 4, 570 08 Ionia,
Thessaloniki, Greece, Tel: (+30 2310 722 506) Fax: (+30 2310 722 086),
email: info@nouris.gr