

AYTOMATIC BOTTOM ASSEMBLING & HANDLE MACHINE

SMA-130&131



NOURIS



SMA130

GENERAL FEATURES:

- Four stitching groups of one stitching head each one. High performance motor with digital inverter for every group. The reviters are auto centering
- Four chains of 1" for the transport of materials. The chains are driven by two servo motors with digital drivers.
- All the functions are controlled by a PLC. A control panel with a touch screen is available for the programming. Up to 10 different programs can be memorized. The adjustment of sizes is very fast due to electro motors for adjustment of width and length.

TECHNICAL DATA:

Total installed power: 12 kW.

Weight: aprox. 4.500 kg

Electric supply : 3x380V+-10% - 50Hz

Consumption of compressed air (max):360 Nlit/min

Pressure of compressed air (min): 6bar

Diameter of wire: 1,2mm

Production up to 2300 boxes/h (the production is theoretical and it depends to the number of stitches and to the height of the boxes)

Distance of stitches: 90-170mm

No of stitches: Side from 1 up to 5 – Head from 0 up to 3 stitches.

Dimension of boxes (external mm): Length:285-600 Width:185-400 Height:60-260.



NOURIS

SMA 130-A

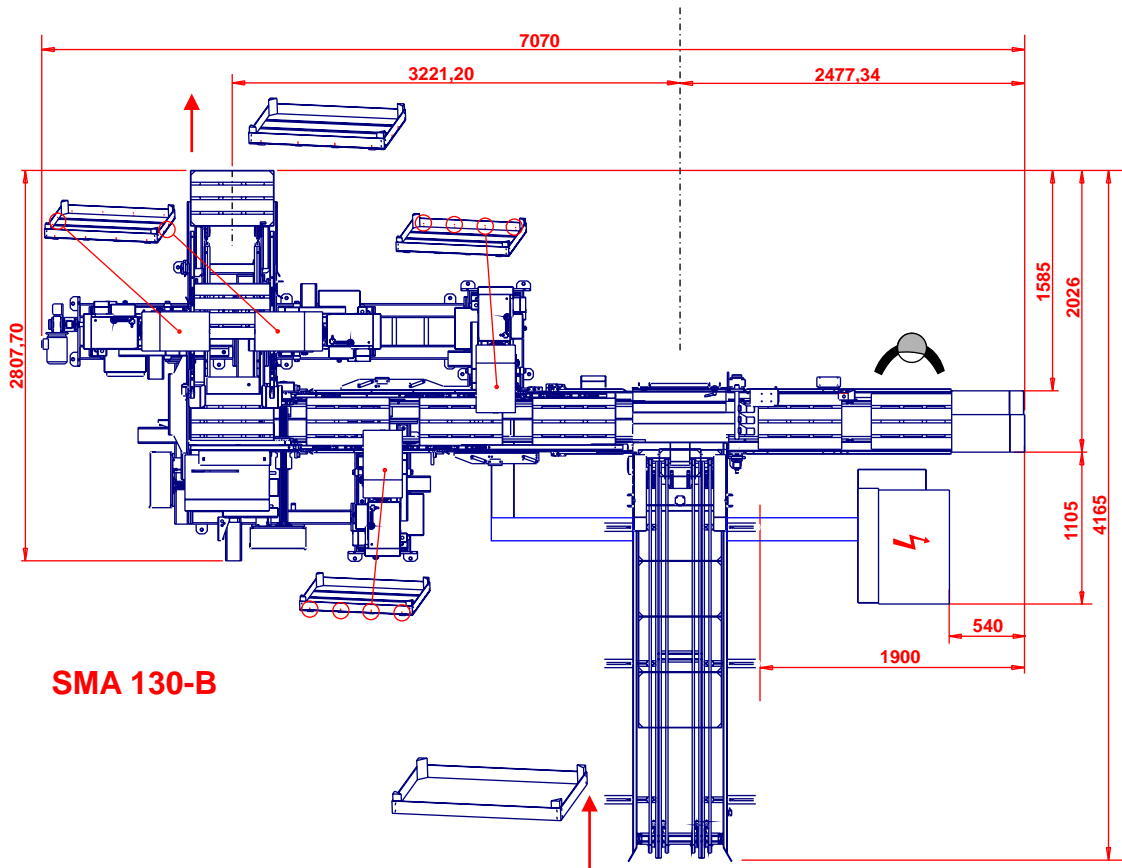
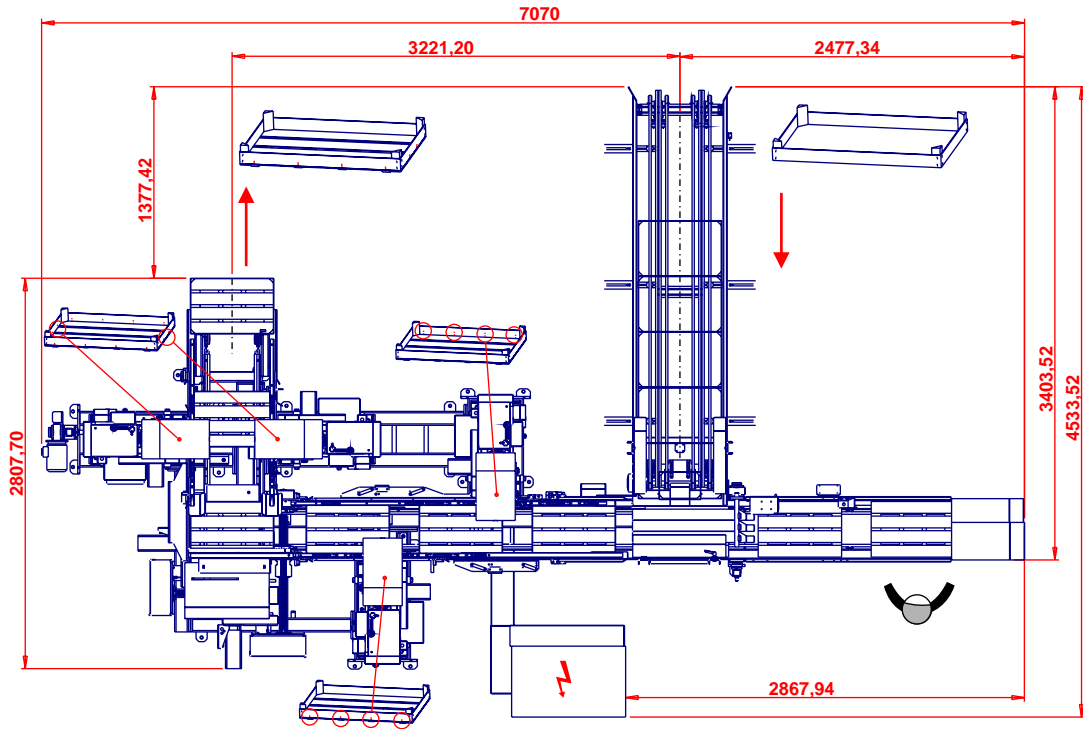

SMA 130-B



NOURIS



SMA131

GENERAL FEATURES:

1. Two stitching heads.
2. Two chains of 1" driven by a digital servo motor.
3. Two automatic handle feeder.
4. Memory of 10 different boxes.
5. Very fast and easy adjustment.

TECHNICAL DATA:

1. Total installed power 5 W.
2. Electric supply: 380 V 50Hz
3. Compressed air consumption: 80 Nlt/min
4. Pressure of compressed air: 6bar (minimum)
5. Wire diameter: 1,2mm
6. Dimensions of stitch: width 7mm - length 22mm
7. Production (theoretical): up to 2500 boxes/hour.
8. Dimension of boxes: Length from 285 up to 600mm
Width from 185 up 400mm
Height from 60 up to 270 mm
9. Weight: aprox.1.200 g

SMA131

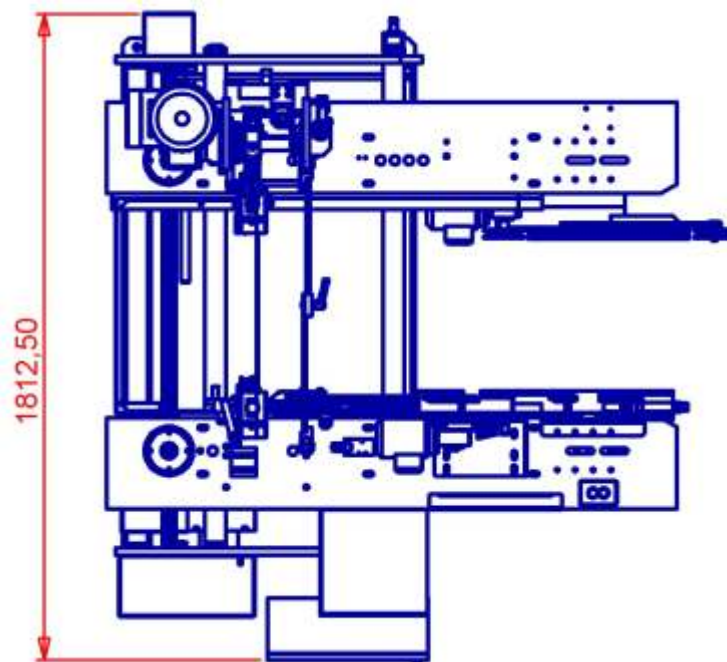
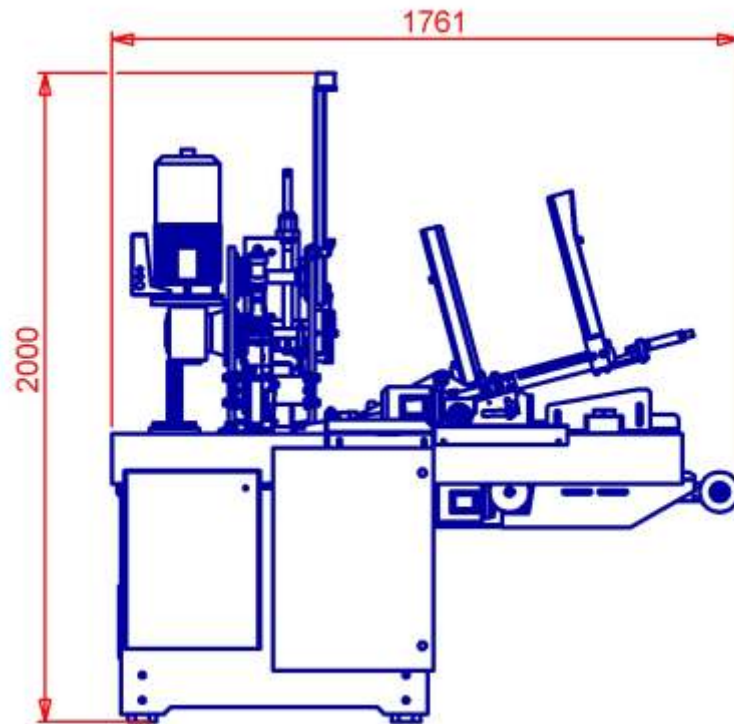

NOURIS

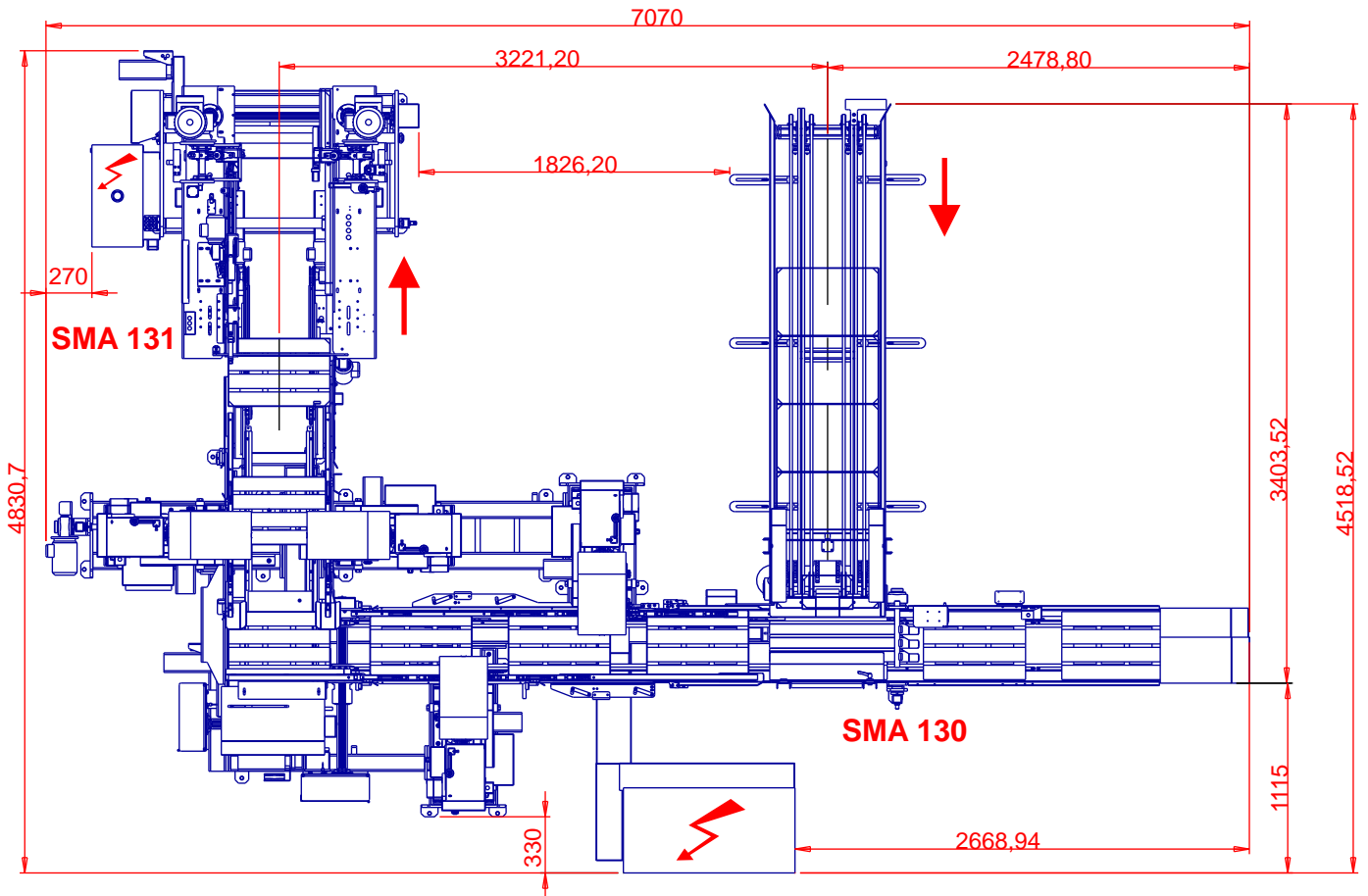

NOURIS

URIS SONS

14th km. old National Road Thessaloniki - Veria
P.O. Box 4, 570 08 Ionia, Thessaloniki, Greece
el: 0030 2310 722 506, Fax: 0030 2310 722 086
http://: www.nouris.gr