

SMA-130&131



NOURIS



SMA130

- T : digital servo μ μ
- μ digital servo 1" μ
- μ μ PLC.
- μ μ 10 μ
- μ : 12 KW.
- μ : 3x380V+-10% - 50Hz
- μ (max):360 Nlit/min
- μ (min): 6bar
- μ μ : 1,2mm
- 2600 boxes/h (μ ,)
- μ : 80-175mm
- μ : 3 5 - 2 3
- (mm): M :285-600 :185-400 :60-260
- : 4.500 kg



NOURIS

SMA 130-A

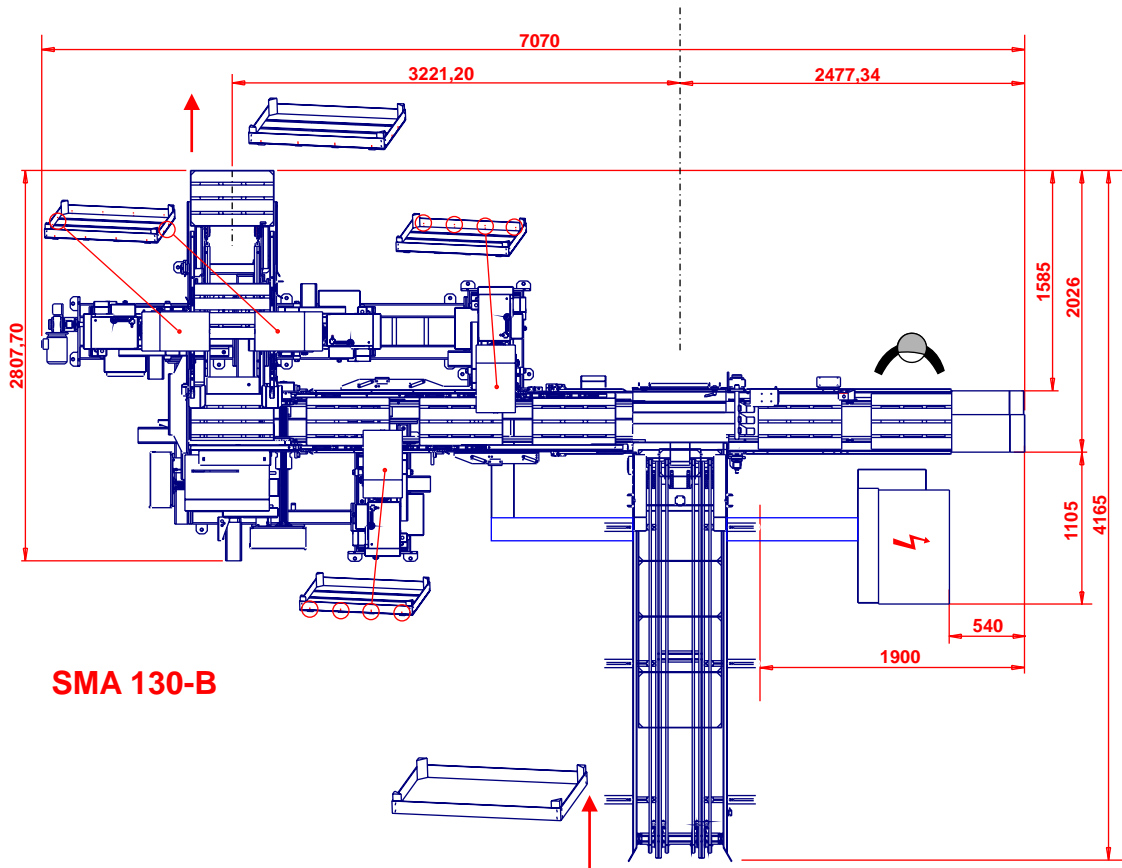
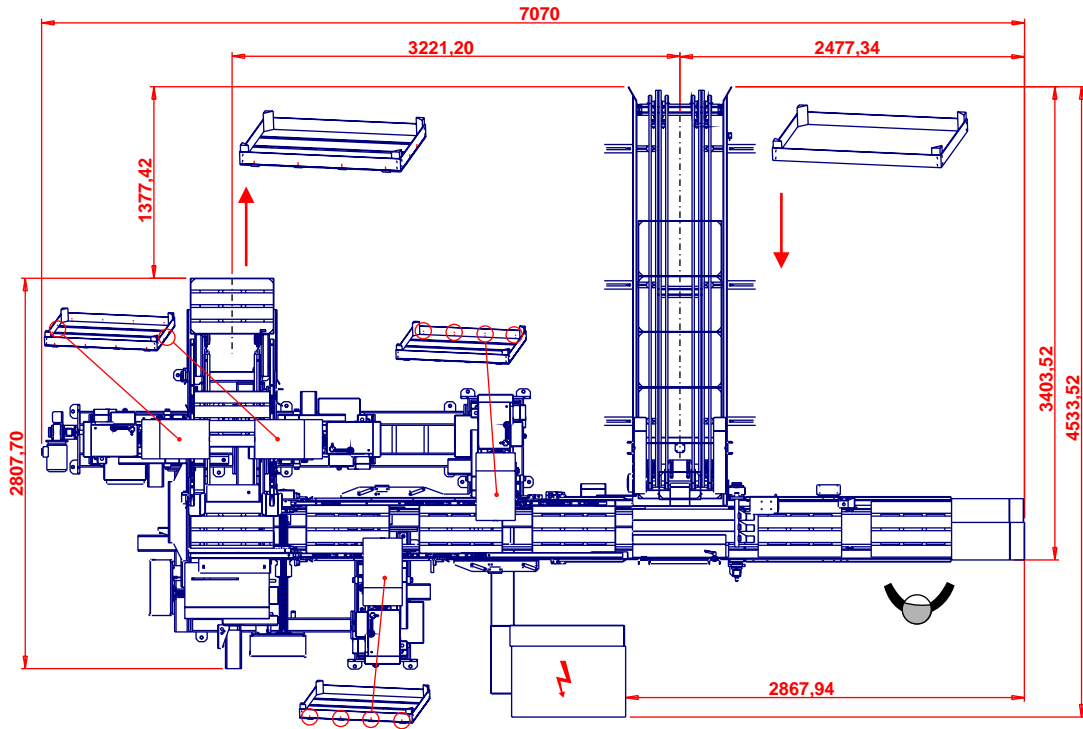

SMA 130-B



NOURIS



SMA131

- 1. :
- 2. . μ 1" μ digital servo.
- 3. μ μ
- 4. μ μ - μμ μ 10 .
- 5. μ - .

- 1. I 5 W.
- 2. . μ : 380 V 50Hz
- 3. μ : 80 Nlt/min
- 4. μ : 6bar (minimum)
- 5. μ μ : 1,2mm
- 6. : 7mm μ 22mm
- 7. : μ 2500 ./ .
- 8. : 285 600mm
185 400mm
60 270 mm
- 9. B μ μ : 1.200 g



NOURIS

SMA131

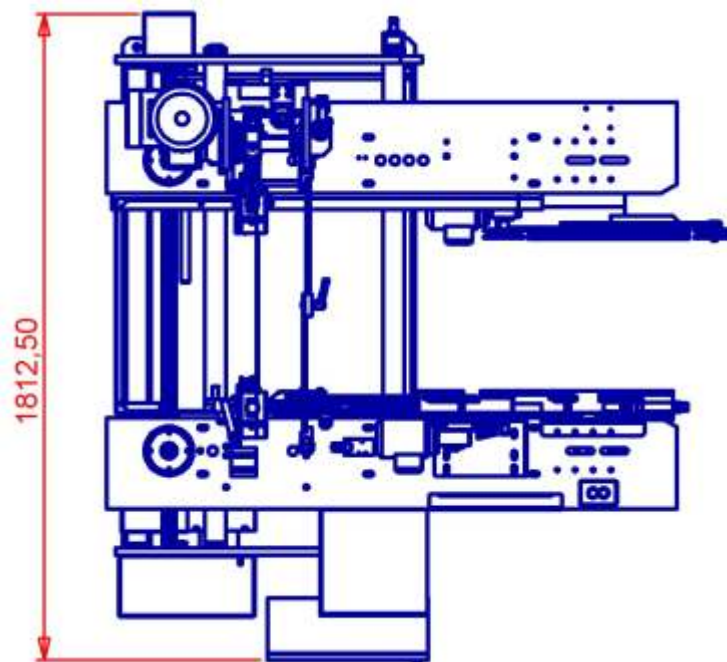
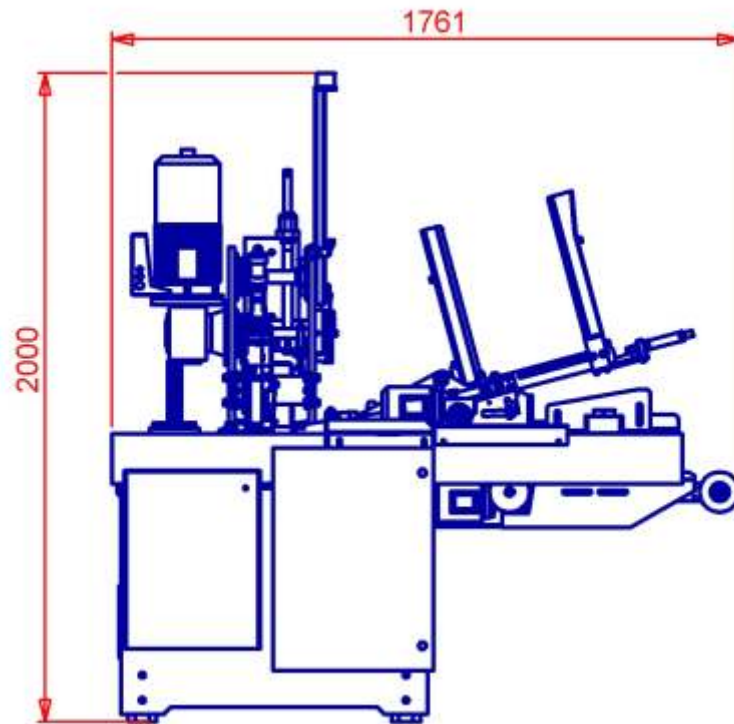

NOURIS

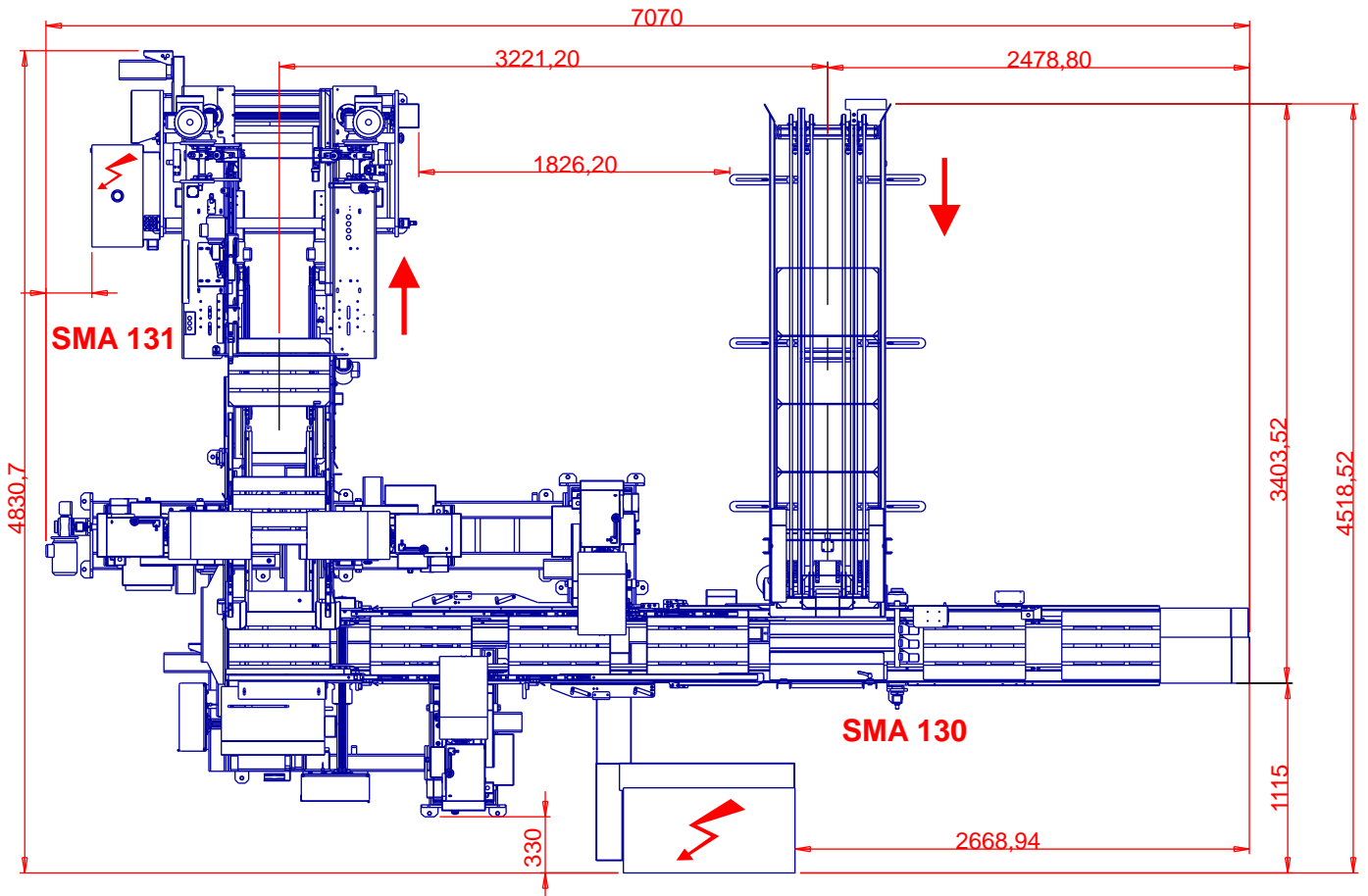

NOURIS

URIS SONS

14 μ. / -
 . . . 4, 570 08
 : 2310 722 506, Fax: 2310 722 086
 http://: www.nouris.gr

14th km. old National Road Thessaloniki - Veria
 P.O. Box 4, 570 08 Ionia, Thessaloniki, Greece
 el: 0030 2310 722 506, Fax: 0030 2310 722 086
 http://: www.nouris.gr